



GLASGOW AVENUE PLANNING STUDY PUBLIC WORKSHOP #3 MAY 22, 2017

Agenda

- **4:30 – 7:00 PM**
 - Sign in
 - View display boards
 - Provide your input
- **6:00 PM**
 - Presentation

The Team

RHODESIDE & HARWELL:
Planning / Design /
Community Engagement



WELLS + ASSOCIATES:
Multi-Modal Transportation
Planning / Engineering



RCLCO:
Market and Economic Analysis

STUDY AREA

TO NEWARK, DE
& UNIV OF DELAWARE

US 40/PULASKI HWY

896

1.3 MILES

GLASGOW AVE

PORTER RD

OLD COUNTY RD

Purpose of the Study

- **The study is intended to create a “Main Street” vision plan to guide transportation improvements and land use along Glasgow Avenue.**
- This section of old SR 896 previously functioned as an arterial roadway with limited access points. With the bypass, Glasgow has become more of a “Main Street,” with mostly local trip to and from businesses, schools, and neighborhoods.
- **With more development planned, this roadway will continue to face mobility and safety challenges.**

This study is an opportunity for community members and other stakeholders to shape future change and have input into how improvements occur over time.

PROCESS AND SCHEDULE



Public Workshop #1
(March 2015)

Public Workshop #2
(June 2015)

Public Meeting #3
(May 2017)

Purpose of Public Workshop #3

- Catch you up on work to date
- Present the final draft concept and guidelines for the corridor





OVERVIEW & GOALS

ELEMENTS OF A MAIN STREET

A mix of uses: A variety of land uses (housing, shops, schools, parks, offices, etc.) in the same area.

People: Enough people for businesses to flourish and for public transit to run frequently.

Destinations: Whether they are shops, public spaces, medical facilities, or other activity hubs.

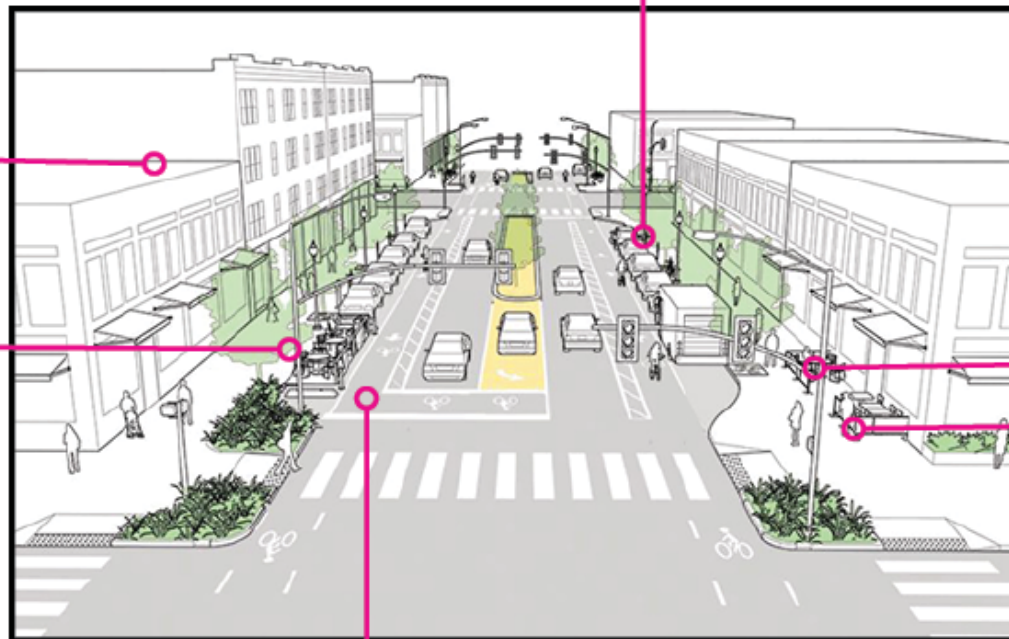

Parks and public spaces: Plenty of public places to meet, gather, and play.

Complete streets: Streets designed to provide safe access for people biking, walking, taking the bus, and driving.

Pedestrian-scale design: Comfortable and spacious sidewalks, with buildings close to the street and large parking lots in the back.

Public Workshop #1 (March 2015)

- Open house & presentation
- Break-out discussion groups
- Materials & survey posted on website



Public Workshop #2 (June 2015)

- Open house & presentations
- Review draft alternatives
- Materials & survey posted on website



Project Goals



Project Goals



HOLISTIC COMMUNITY



- Create pedestrian and bicycle **links to existing and planned regional trail facilities**
- Create pedestrian and bicycle **connections between corridor amenities**
- Provide **family-friendly community amenities**



COHESIVE CORRIDOR



- Create a **unified visual identity** through street design, landscape, signage, lighting and street furniture
- Define “**gateways**” at the Glasgow intersections with US 40 and SR 896
- **Link the corridor** to popular destinations and adjacent neighborhoods Create design guidelines for the corridor to **guide future development**

Project Goals



- Provide spaces for a **diversity of uses and activities**
- Design a “complete street” for Glasgow that allows for **safe and comfortable walking and biking**
- Allow **2-3 story buildings** fronting on Glasgow Avenue north of Cann Road
- **Reduce the speed limit** and enforce it more effectively



Project Goals



- Design facilities for people to **conveniently and safely drive, walk, bike, and use transit**
- **Manage speed** with lanes that are not excessively wide and with vertical elements (buildings, trees) pulled up closer to the sidewalk
- **Improve intersection conditions** at Old County Road
- Provide **convenient and accessible bus stops** on Glasgow Avenue



- Add **trees and landscaping** to the edges of the roadway and a median as appropriate
- **Protect and enhance** the existing environmentally sensitive areas
- Add ecologically sound **stormwater management** practices

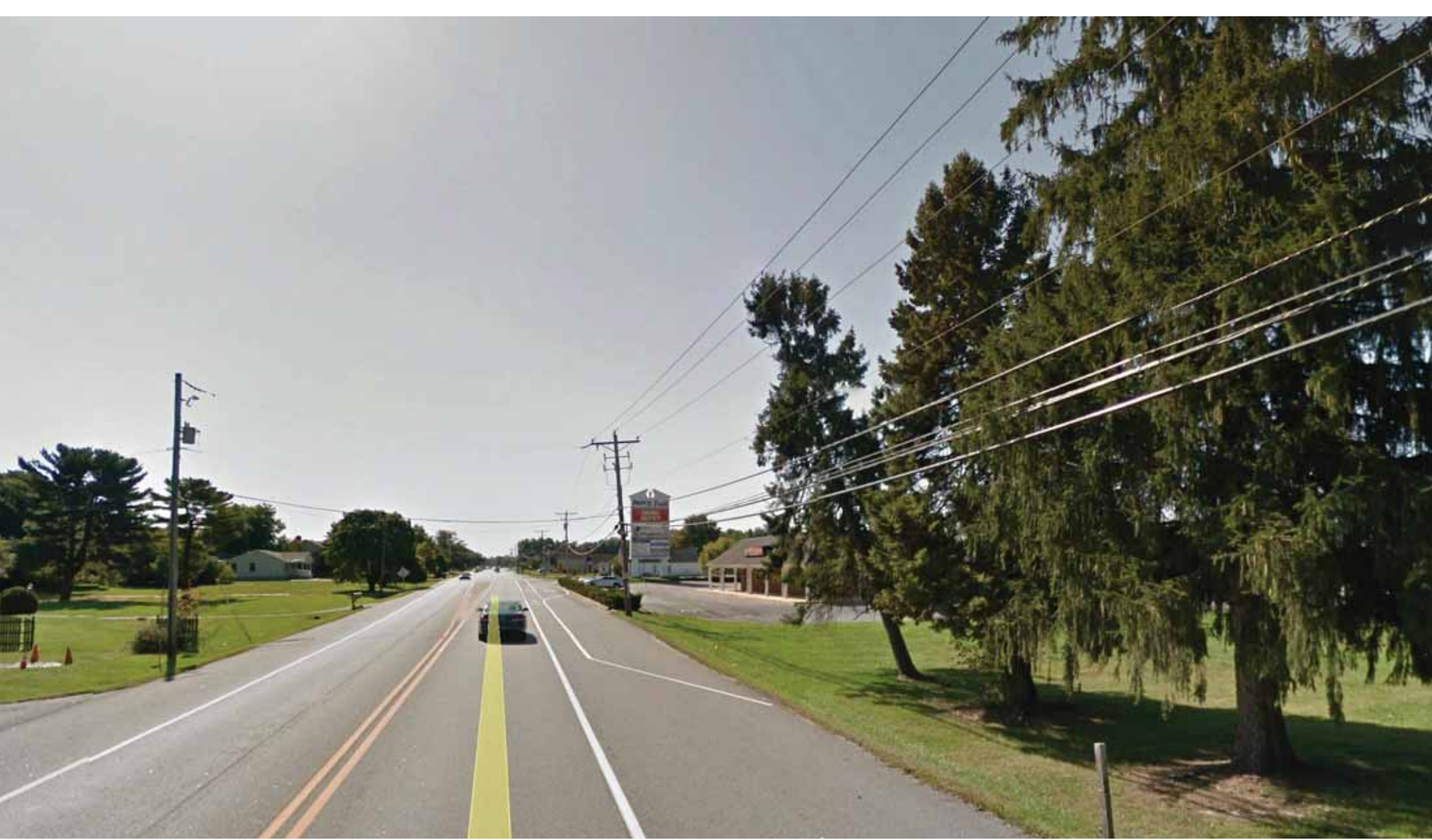

EXISTING CONDITIONS

BARRIERS TO THE MAIN STREET VISION



Prominent powerlines

Parking lot in front of buildings

Buildings set back too far from road

Not enough places to cross

Few street lights

Unprotected bike lanes

Few sidewalks

Few street trees

Excess pavement

BICYCLE AND PEDESTRIAN CONDITIONS

Current Bicycle Lane



Pedestrian Conditions Vary



BUILT ENVIRONMENT

- Buildings set far back
- Unused / underdeveloped parcels
- Parking in front of buildings
- Opportunities for infill development





DEVELOPMENT OF RECOMMENDATIONS

PROCESS

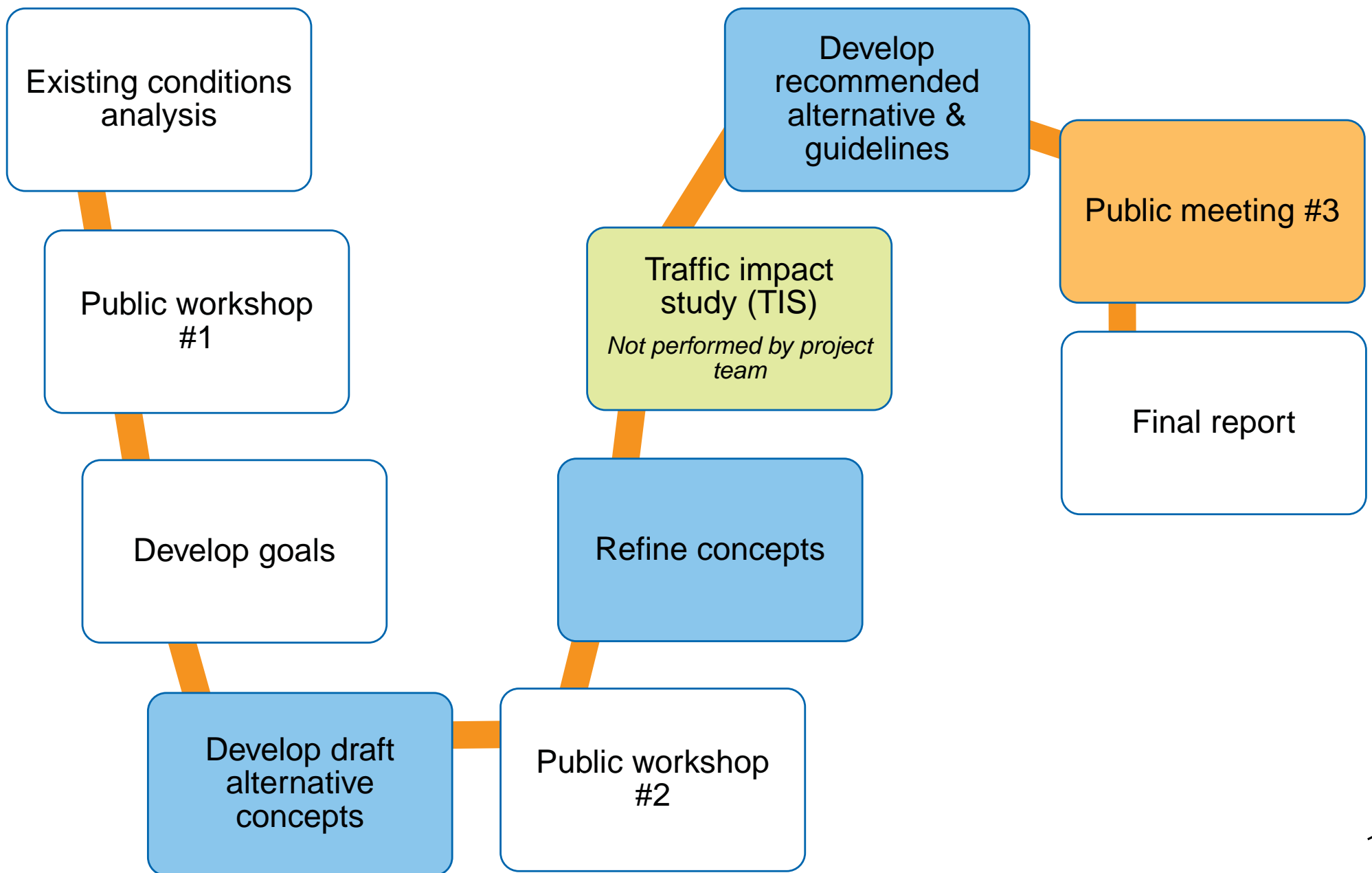

PURPOSE OF THE TRAFFIC IMPACT STUDY

- The TIS examined potential impacts to traffic operations caused by the proposed development at the southeastern corner of Glasgow Avenue & US 40 / Pulaski Highway.
- **This study was not completed as part of the Glasgow Avenue Planning Study, but it does have important implications for the creation of a “main street” along Glasgow Avenue.**



TIS FINDINGS

- The County's assessment indicates that **while the proposed development could impact traffic operations, the developer has identified acceptable improvements.**



IMPACT ON THIS STUDY

- The TIS states that, “**The developer should construct a bike lane and sidewalk consistent with the Glasgow Avenue Planning Study** along the easterly side of Glasgow Avenue from US Route 40 to the South Entrance to Peoples Plaza that meets current standards.”
- Requires changes to intersection operations
- Supports addition of Abbey Road



PROCESS

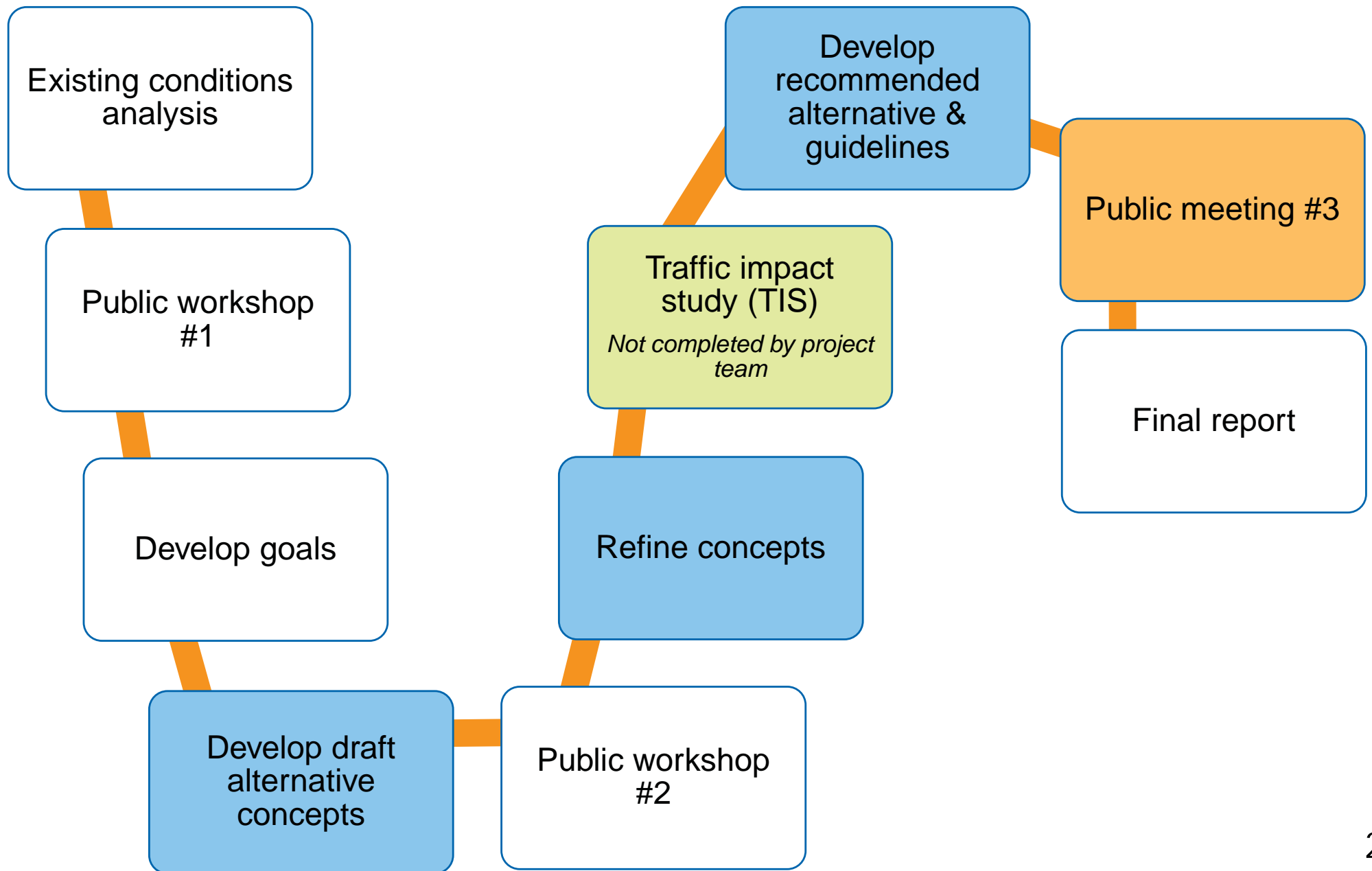







DRAFT PROPOSED CONCEPTS

CHARACTER DISTRICTS



- Four Character Districts, based off of existing conditions
- Distinct districts with a cohesive corridor theme

-  Village Center
-  Institutional
-  Residential
-  Southern Gateway

PEDESTRIAN AND BICYCLE CONNECTIVITY

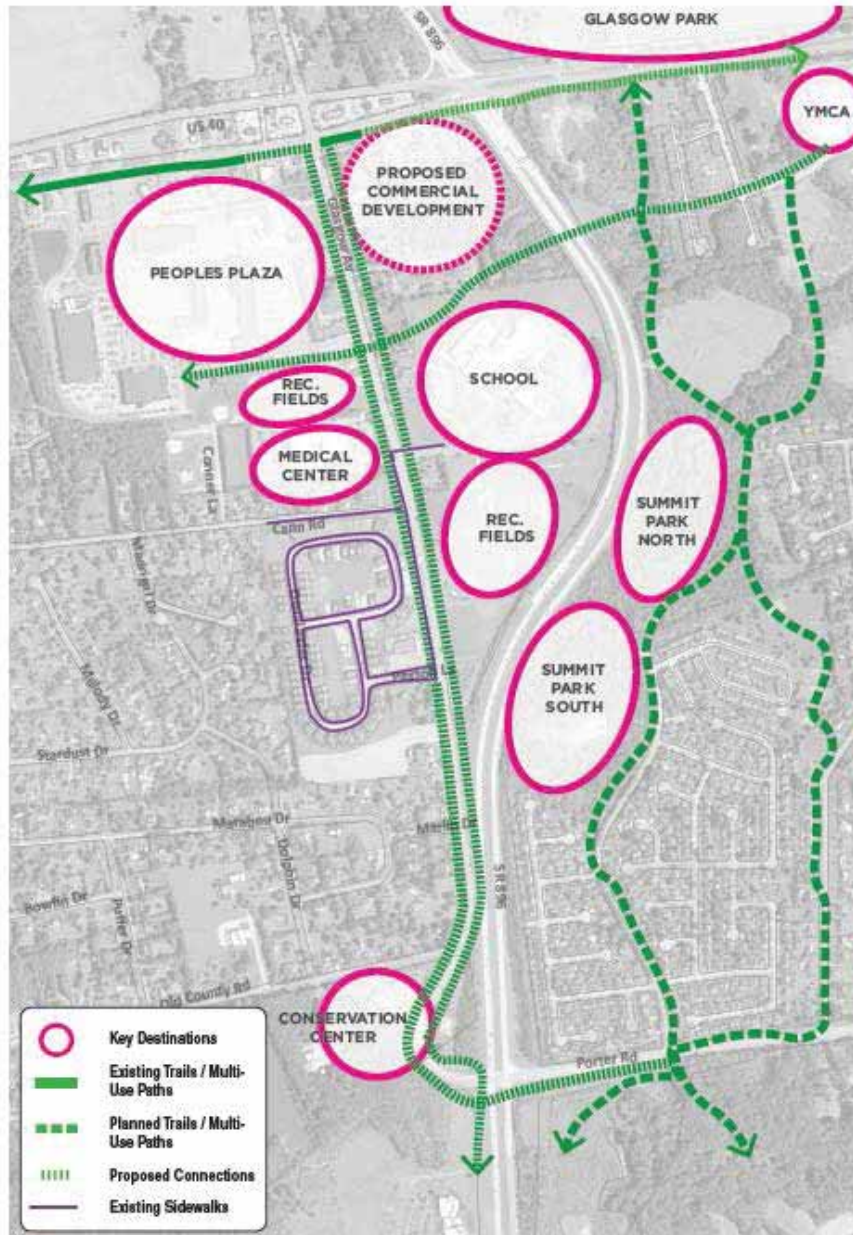

- Links within the corridor
- Links to destinations and residential areas outside the corridor

GLASGOW AVENUE EXISTING CONDITIONS

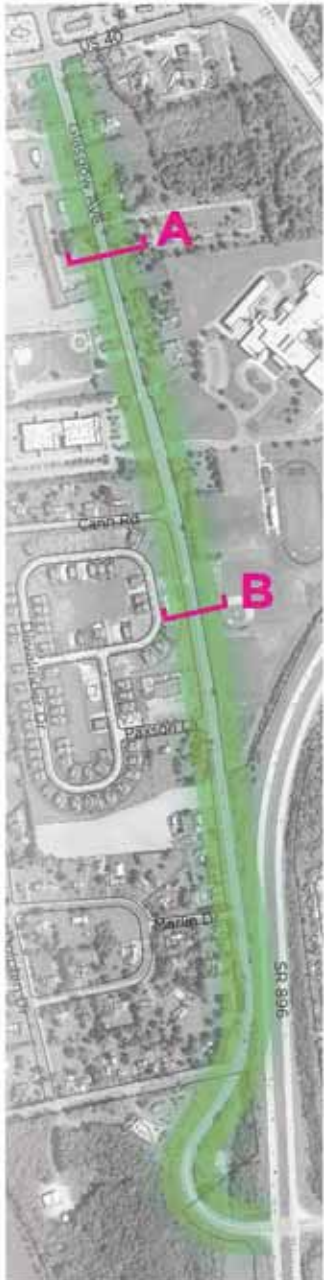

EXISTING CROSS SECTION [A]

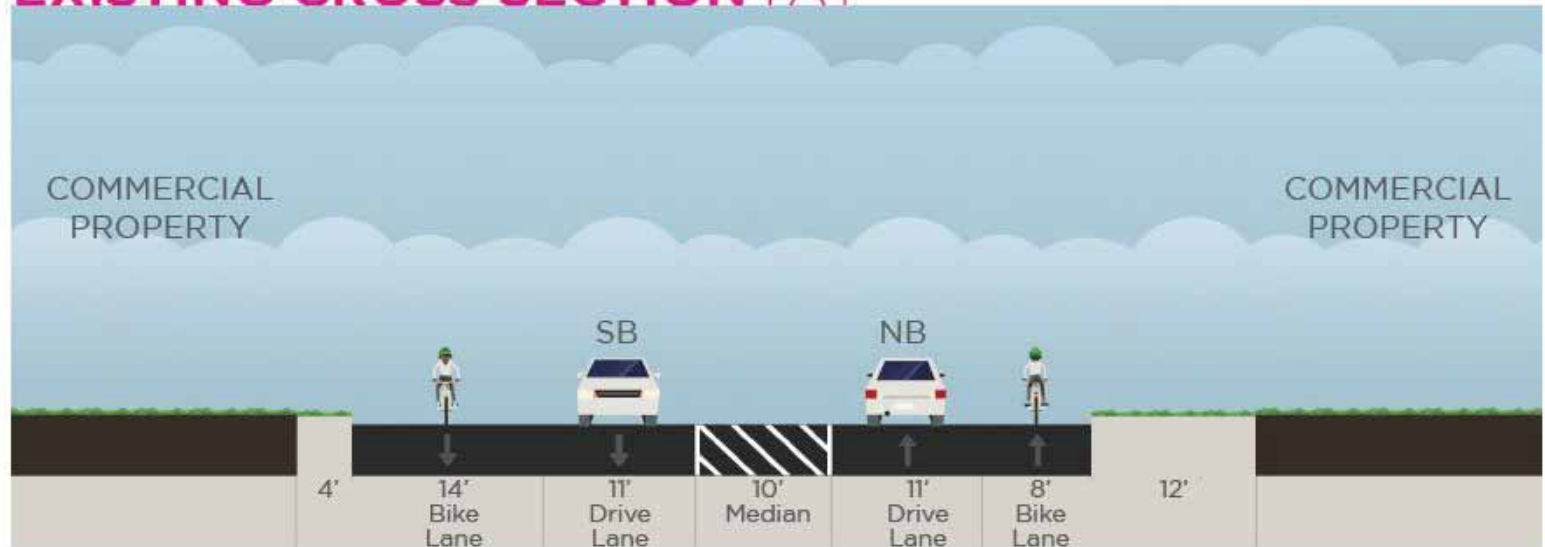

EXISTING CROSS SECTION [B]



GLASGOW COMPLETE STREET CONCEPT

Buffered bike lanes + sidewalk (north)



Multi-use paths (south)



RECOMMENDED CONCEPT

BUFFERED BIKE LANES, SIDEWALKS, AND MULTI-USE PATHS

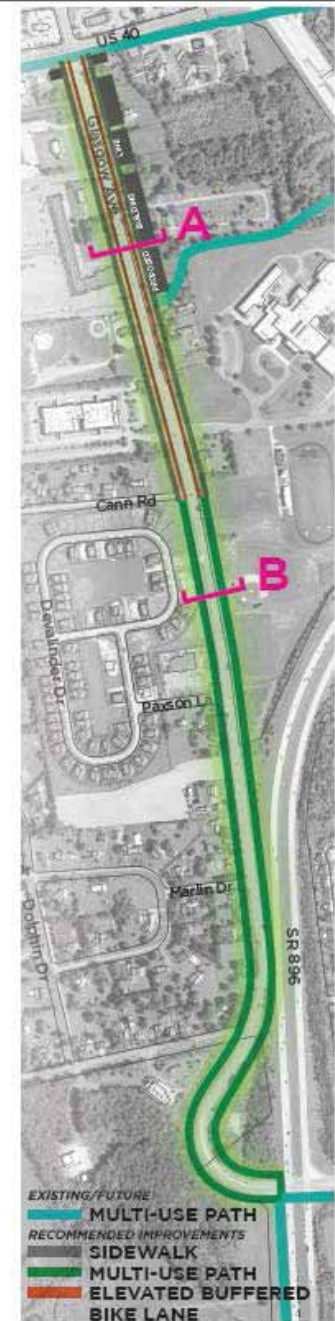

PROPOSED CROSS SECTION [A]



ON-STREET PARKING WOULD REQUIRE ADDITIONAL RIGHT-OF-WAY

PROPOSED CROSS SECTION [B]

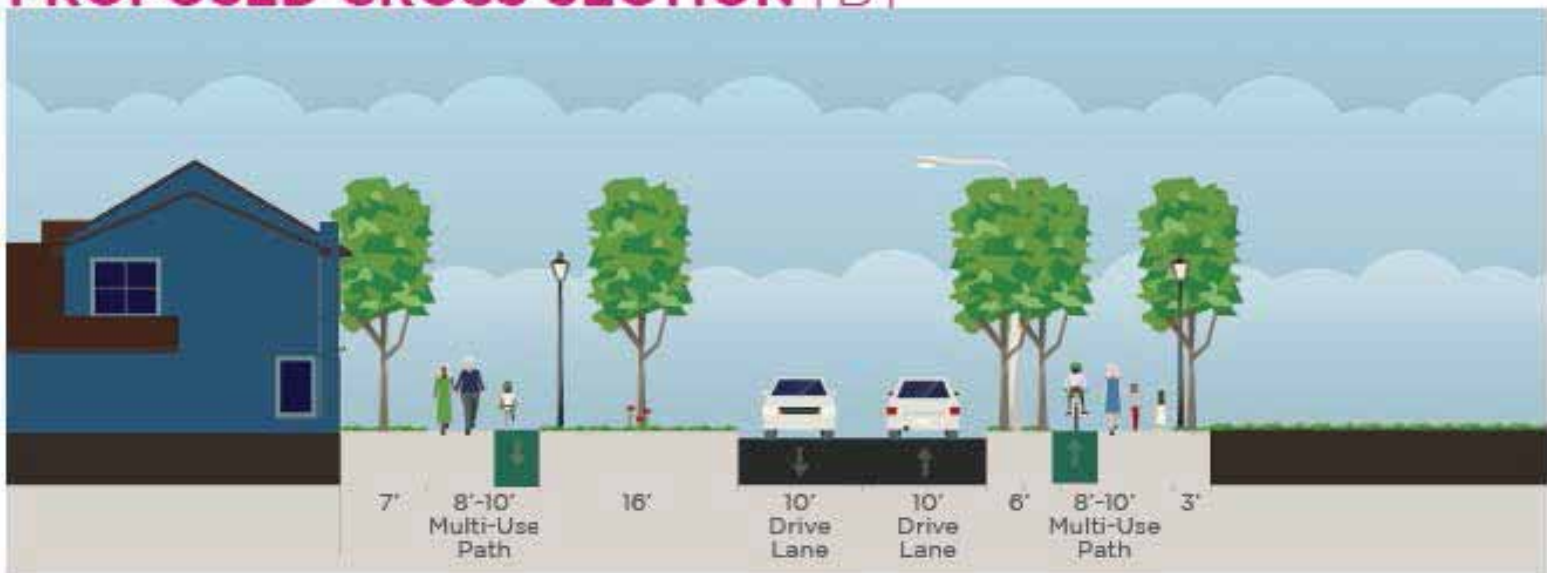

HIGHLIGHT: VILLAGE CENTER

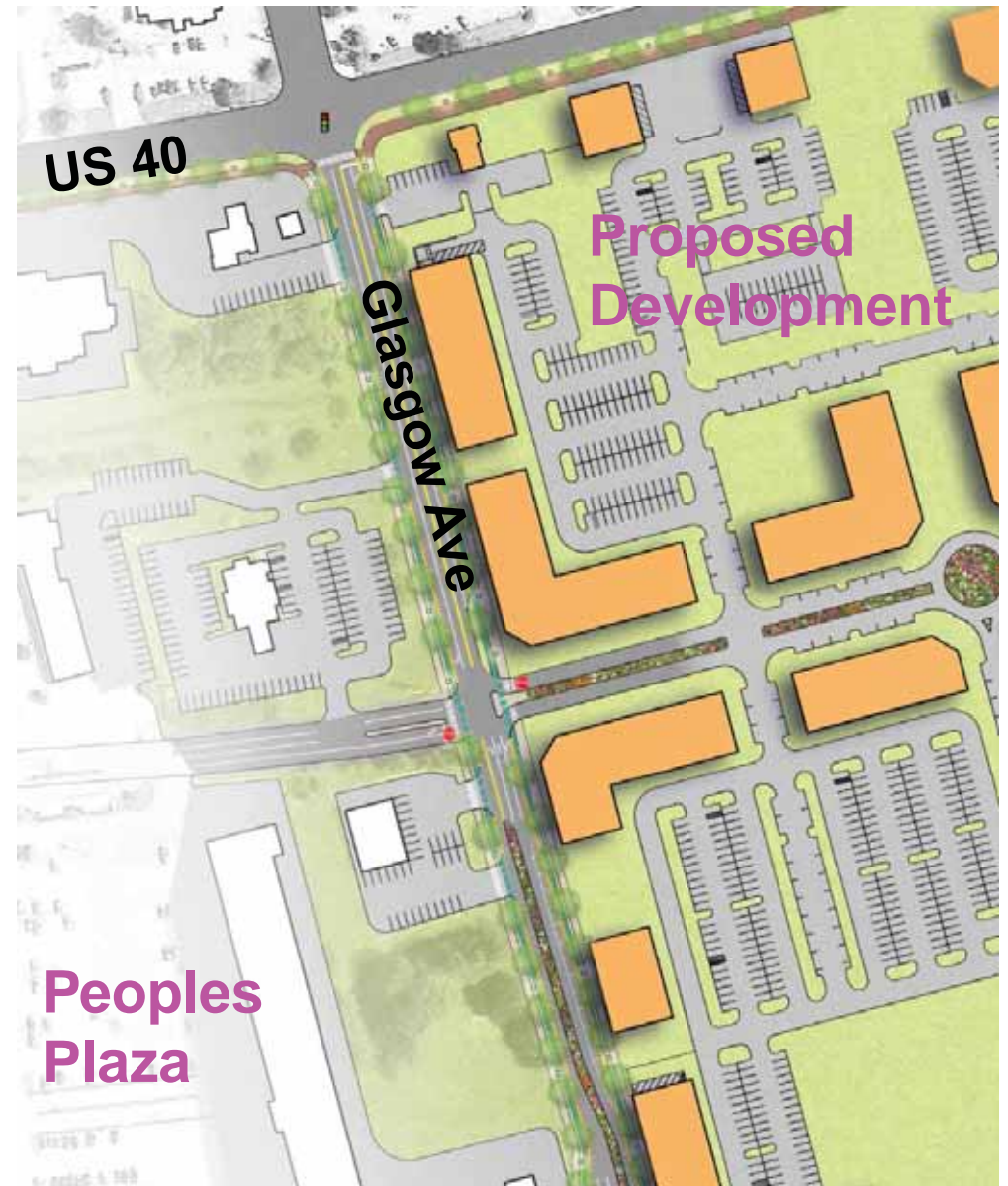

HIGHLIGHT: PROPOSED ABBEY ROAD

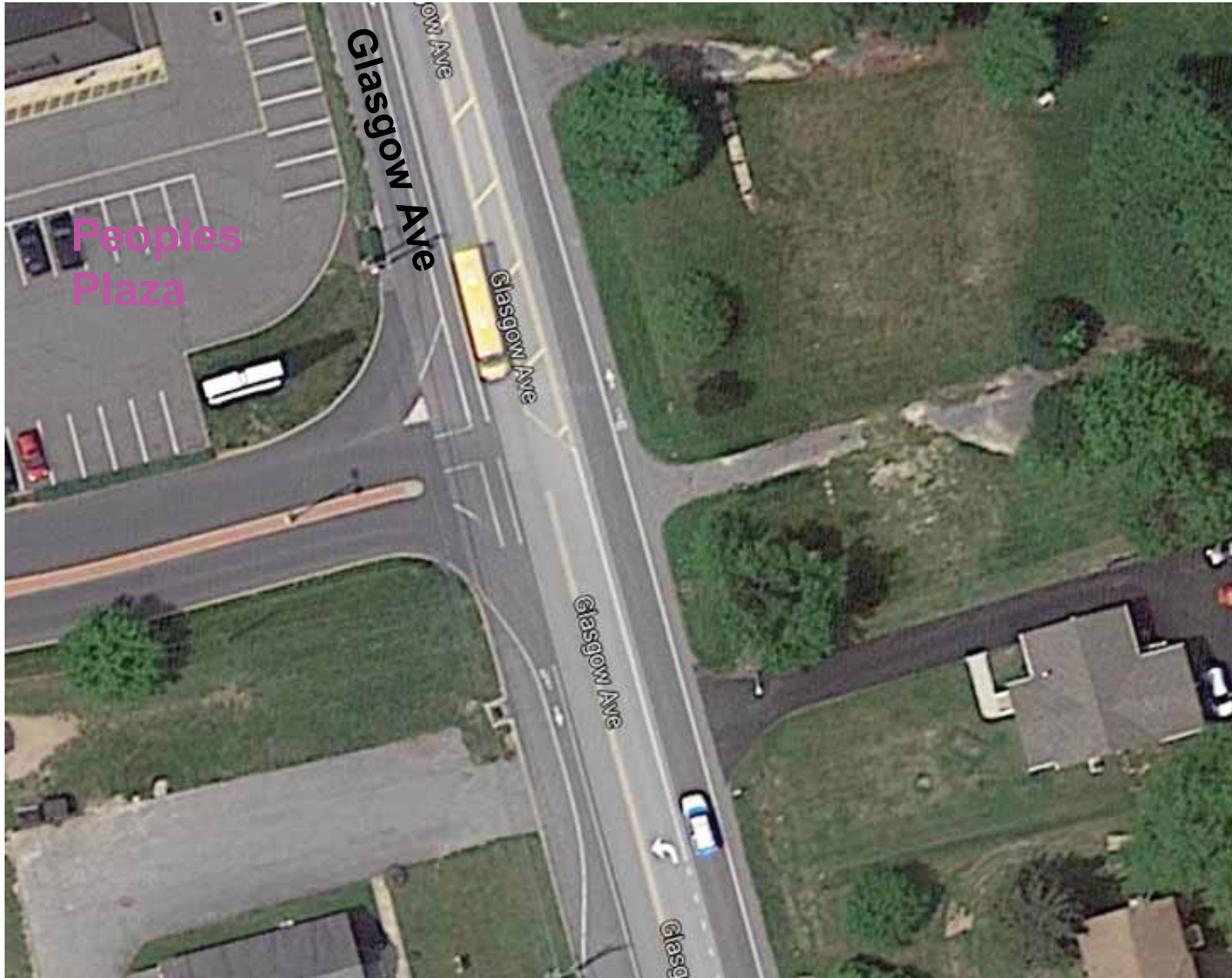

HIGHLIGHT: PROPOSED ABBEY ROAD

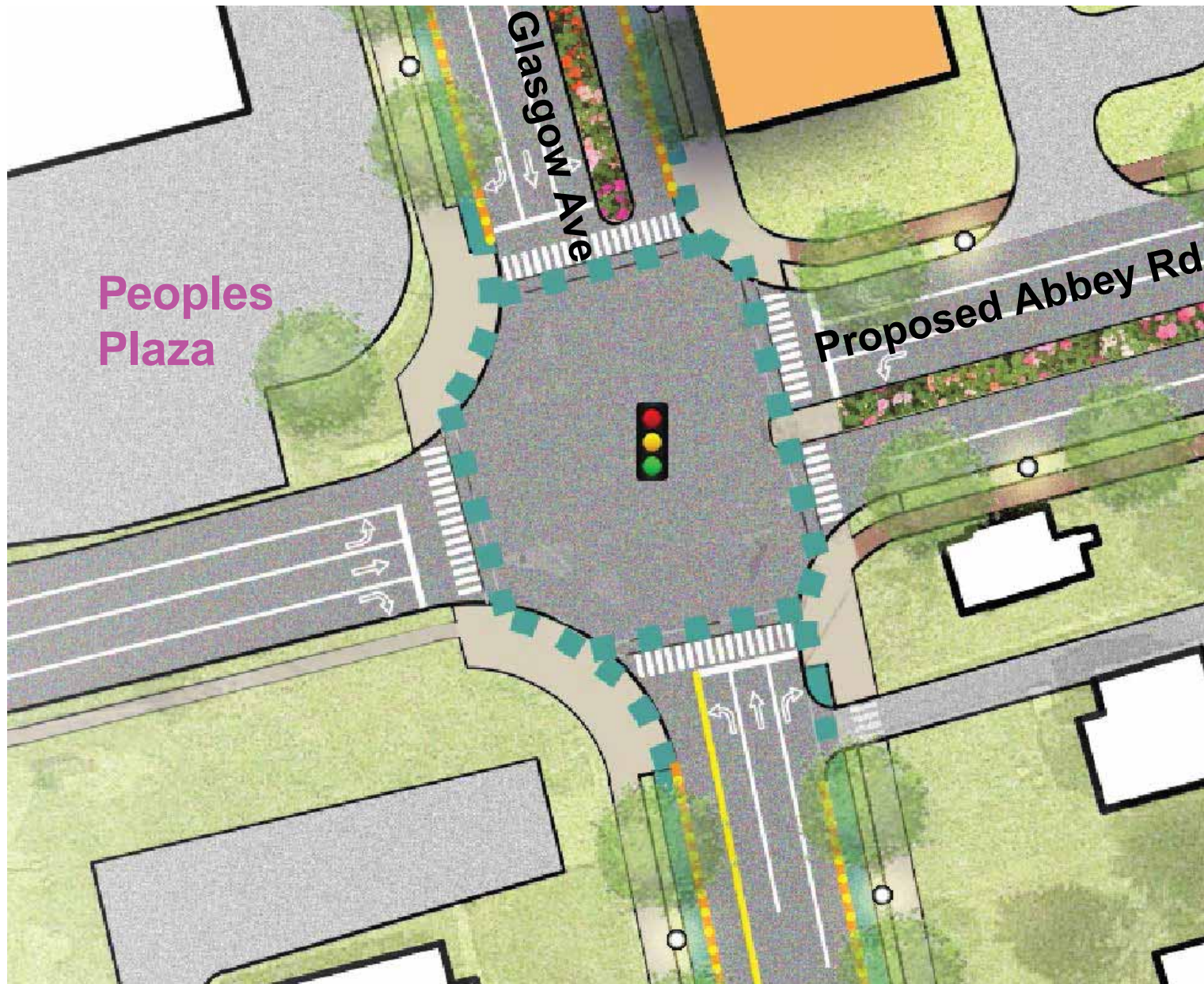

- Existing Buildings
- Buildings Proposed by Reybold Development Plan
- Proposed Bicycle Lane
- Proposed Bicycle Lane Buffer
- Proposed Multi-use Path
- Proposed Sidewalk
- Proposed Median Plantings
- Proposed Trees
- Vehicle Travel Lanes
- Parking Areas

HIGHLIGHT: PROPOSED ABBEY ROAD



HIGHLIGHT: PROPOSED ABBEY ROAD





HIGHLIGHT: OLD COUNTY ROAD

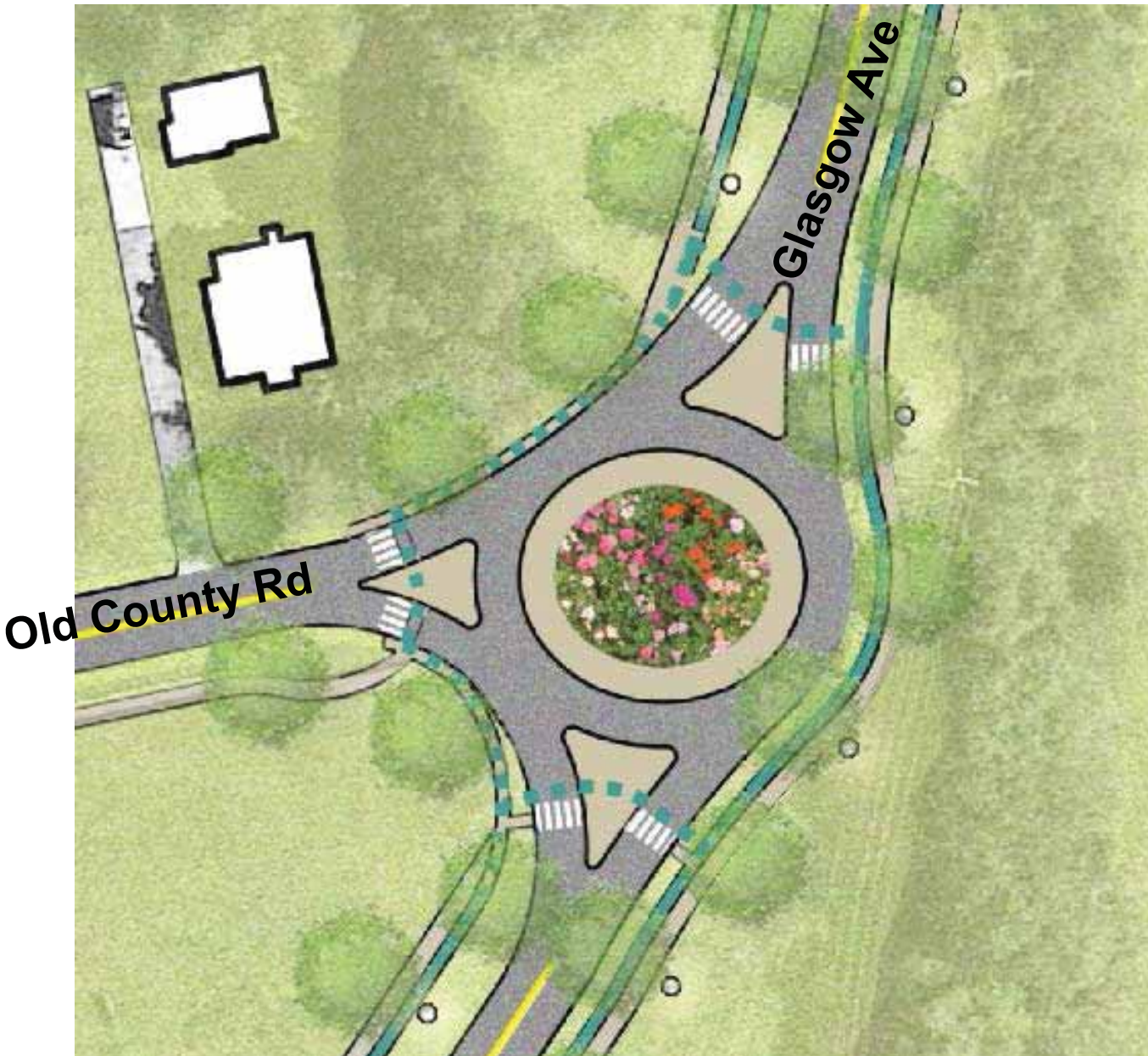

HIGHLIGHT: OLD COUNTY ROAD



-  Existing Buildings
-  Proposed Bicycle Lane
-  Proposed Median (with Plantings)

LAND USE AND DEVELOPMENT

- **Activating vacant parcels with development, public parks, or other improvements fosters a more walkable, livable community.**
- There are several parcels adjacent to Glasgow Avenue which are vacant. Other parcels may be ready for redevelopment.
- **These parcels present opportunities to support the Main Street vision by utilizing the guidelines that will be set forth in this plan.**





IMPLEMENTATION

TOOLS FOR IMPLEMENTATION

- Site and Building Design Guidelines
- Street Design Guidelines

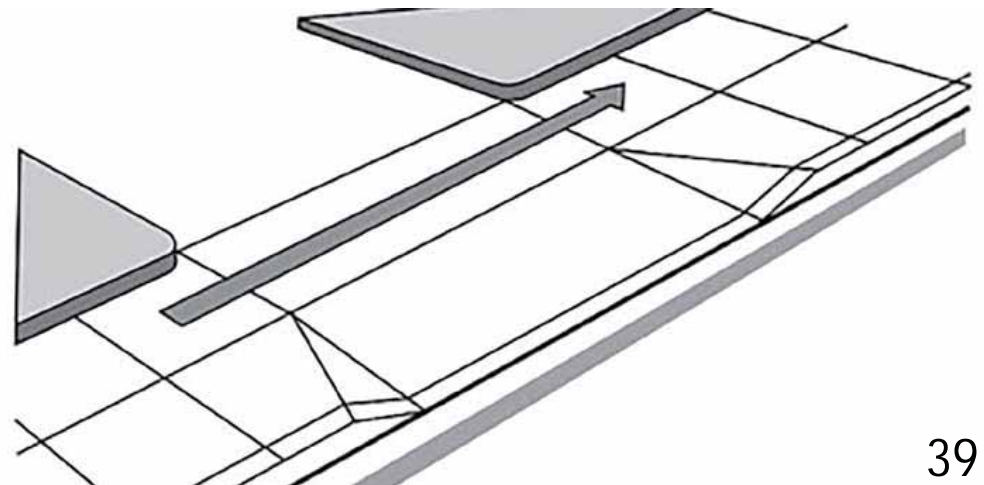
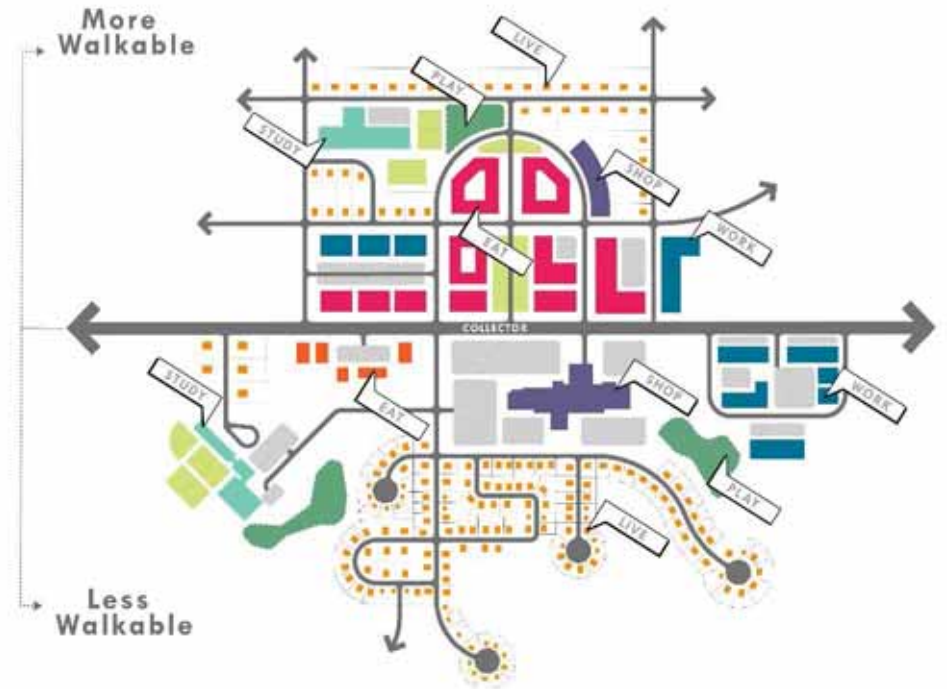

SITE & BUILDING DESIGN GUIDELINES

- The Site and Building Design Guidelines are standards targeting the built environment around the street.
- This includes the building envelope and its features along Glasgow Avenue, access to buildings, and off-street parking lots immediately adjacent to Glasgow Avenue corridor.
- The graphics on the boards demonstrate a few general guidelines regarding sites and buildings.

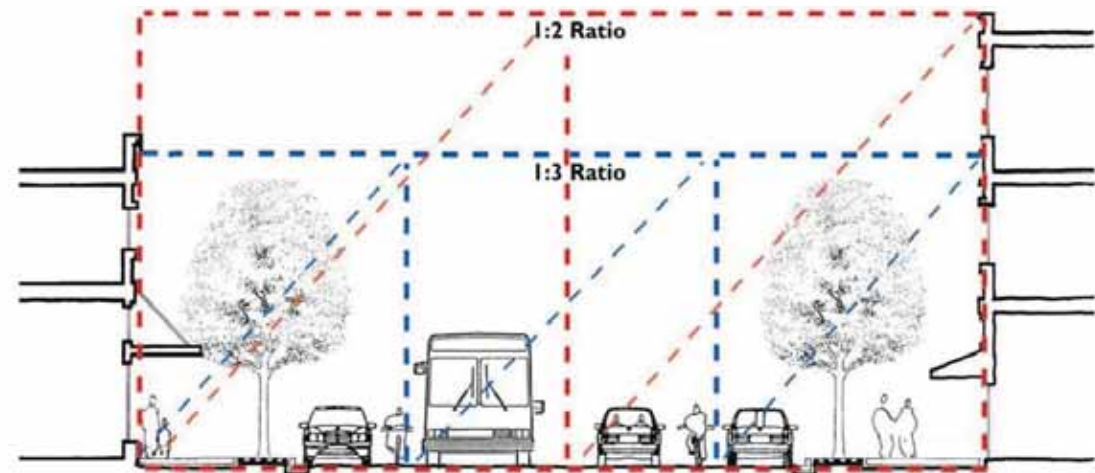
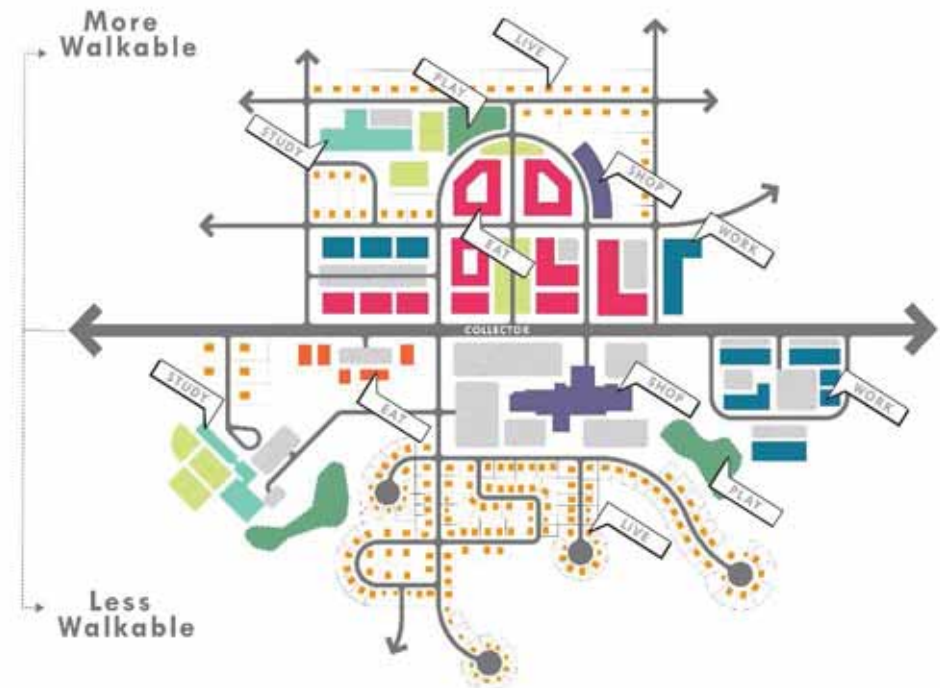

STREET DESIGN GUIDELINES

- The Street Design Guidelines focus on public realm areas along Glasgow Avenue.
- This includes building amenity zones, sidewalks, bike lanes, multi-use paths, tree lawn areas, auto lanes, and any applicable medians.
- The graphics on the boards demonstrate a few general guidelines regarding street design.
- **Please review the matrix of draft guidelines and let us know what you think!**

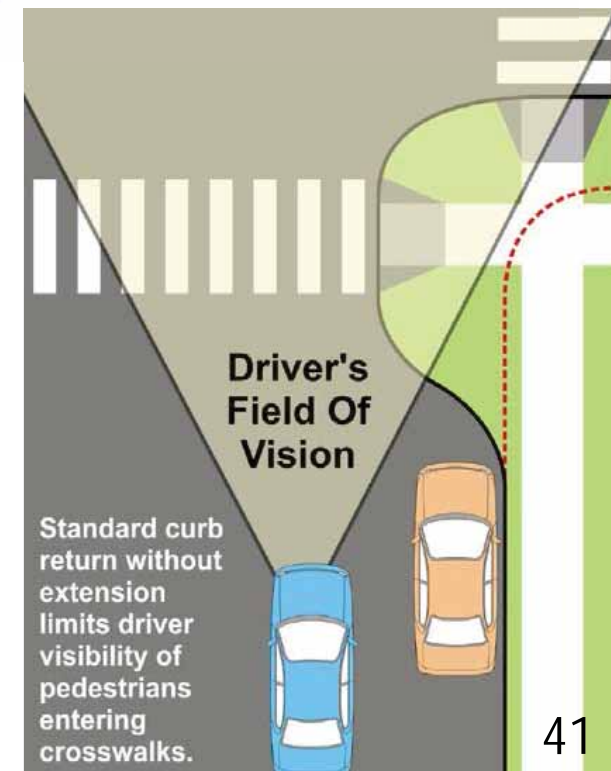
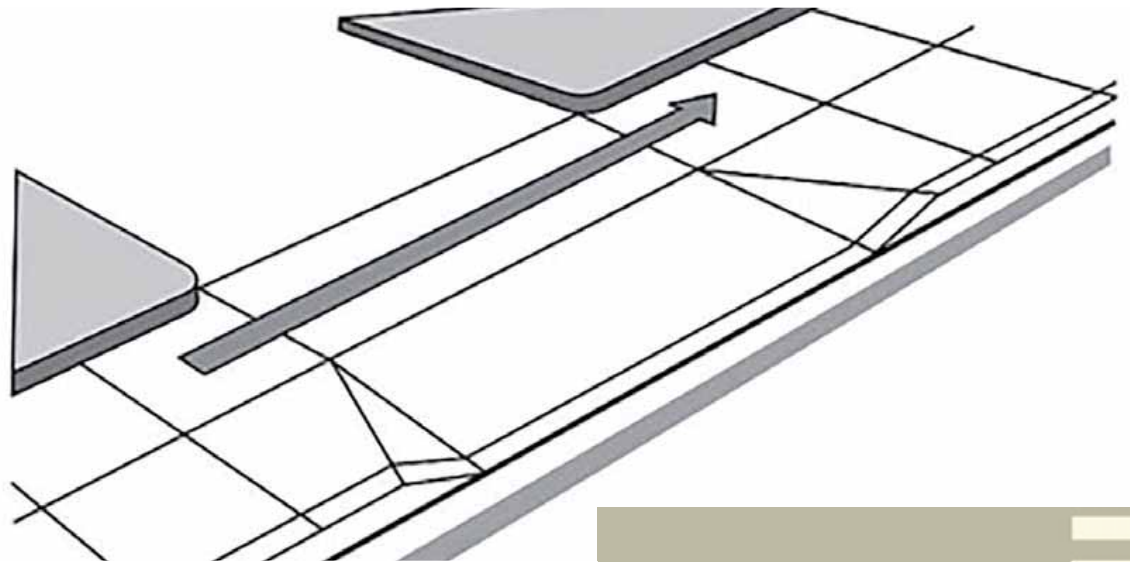

IMPLEMENTATION: NEXT STEPS

- Changes will happen gradually
- **The goal is to have a plan in place that describes a clear community vision for development to follow when it occurs**



IMPLEMENTATION: NEXT STEPS

Finalize the Glasgow Avenue Main Street Study recommendations.

Review the plan (all Project Partners).

Consider incorporation into the County Comprehensive Plan, the Route 40 Corridor 20-Year Transportation Plan and/or the County's Unified Development Code.

Implement transportation improvements as part of proposed developments, or through programming into the 6 Year Capital Transportation Program (CTP).

Incorporate design guidelines into development / redevelopment plans.



Thank You for Attending Tonight's Meeting!

If you have any questions or comments, please contact:

Dave Gula, Project Manager

dgula@wilmaco.org

(302) 737-6205

Project Website:

<http://www.wilmaco.org/glasgow/>

THANK YOU